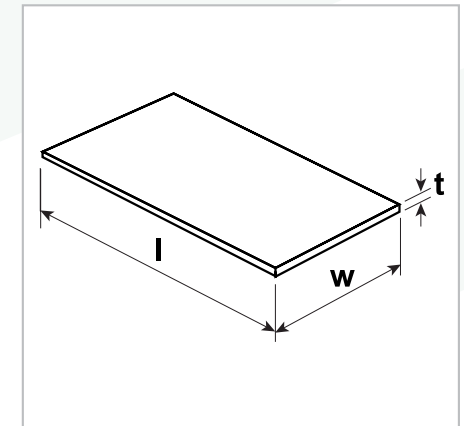

PLATE PRODUCTS REFERENCE GUIDE: QUENCH & TEMPERED PLATE (Q&T) - 500 GRADE

Designation	Weight	Thickness t	Width w	Length l	Designation	Weight	Thickness t	Width w	Length l
	kg/m ²	mm	mm	mm		kg/m ²	mm	mm	mm
2485x8000	62.80	8	2485	8000	2485x8000	314.00	40	2485	8000
2485x8000	78.50	10	2485	8000	2485x8000	392.50	50	2485	8000
2485x8000	94.20	12	2485	8000	2485x6000	471.00	60	2485	6000
2485x8000	125.60	16	2485	8000	1900x6000	549.50	70	1900	6000
2485x8000	157.00	20	2485	8000	1900x6000	588.75	75	1900	6000
2485x8000	196.25	25	2485	8000	1900x6000	628.00	80	1900	6000
2485x8000	251.20	32	2485	8000	1525x6000	785.00	100	1525	6000



- *Manufactured to manufacturers own internal specifications.*

